

Hodgkin Lymphoma (HL): Diagnosis, Treatment and Side Effect Management



1

Learning Objectives

- Describe the various subtypes of Hodgkin lymphoma (HL)
- Identify tests used to diagnose disease and monitor treatment of HL
- Explain the overarching goals of treatment for the subtypes of HL
- Explain approved and emerging treatment options for HL, including stem cell transplantation, and the role of clinical trials
- Describe strategies to manage treatment side effects as well as potential long-term and late effects of treatments for HL
- Describe the roles of the pharmacist, the nurse, and the social worker in treating patients classical HL



2

Faculty

Matthew Matasar, MD
 Chief of Blood Disorders
 Rutgers Cancer Institute of New Jersey
 New Brunswick, NJ

David Awad, Pharm D, BCOP
 Clinical Pharmacist Specialist
 Division of Blood Disorders
 Rutgers Cancer Institute of New Jersey
 New Brunswick, NJ



3

Disclosures

David Awad, Pharm D, BCOP, has no financial relationships with ineligible companies.

Matthew Matasar, MD, has financial relationships with the following companies:

Advisory Board: Allogene, Epizyme, Genmab, Genentech, Kite, Merck, Regeneron

Consultant: AbbVie, AstraZeneca, Bristol Myers Squibb, Epizyme, Novartis, Regeneron, Roche, Pfizer

Research Support: ADC Therapeutics, AstraZeneca, Bristol Myers Squibb, Epizyme, Johnson & Johnson, Kite, Regeneron, Roche, Pfizer

Tara McCabe, APN, AOCNP, MSN, has no financial relationships with ineligible companies.



4

Roadmap

Overview of Hodgkin lymphoma

Treatment of newly diagnosed Hodgkin lymphoma

Treatment of relapsed or refractory disease

Emerging and novel therapies



LEUKEMIA &
LYMPHOMA
SOCIETY™

5

In The Beginning...

THE
BOSTON MEDICAL AND SURGICAL
JOURNAL.

VOL. VI.] WEDNESDAY, MARCH 28, 1838. [NO. 7.

ABSORBENT GLANDS AND SPLEEN.

On some Morbid Appearances of the Absorbent Glands and Spleen.
By D. HENRIK.

If there be any accounts in books relative to morbid alterations of structure like those about to be described, they can be but little known; the author knows of none, and there is the more room and apology for the present observations.

1. The first case deserving of notice is that of Joseph Simont, nine years of age, a patient in Gray's Hospital, admitted labouring under tædies and effusion into the prepuce and scrotum.

Inspection.—Serous effusion under the arachnoid and within the ventricles. Substance of the brain soft and flabby. Pæneæ much affected with adhesions; fluid in the cavity. A few tubercles in the lungs. Heart healthy. Peritonæum had been recently and extensively inflamed; a sero-purulent effusion in the cavity. Viscera overlaid generally with a soft light-yellow coagulam. The mesenteric glands enlarged—one or two considerably so, equalling in size a pigeon's egg, of semitranslucent hardness, and streaked with black matter. Liver pretty natural. Spleen large, and containing numerous tubercles. Kidneys mottled, of a light color. A continuous chain of much-enlarged, indurated, absorbent glands, accompanied the aorta throughout its course, closely adherent to the bodies of the vertebrae, and extending along the sides of the iliac vessels, so far as they could be traced in the pelvis; none of these vessels had been sufficiently compressed to occasion a coagulation of the contained fluids.

2. The next case is that of Ellenborough Kieg, aged ten years, a patient of Dr. Bright. Until thirteen months ago this child had been healthy; a tumor was then observed in the left hypochondrium, which, under treatment, was very considerably reduced; the glands on both sides of the neck were swollen, the abdomen was somewhat distended, and there was considerable oedema of the scrotum.

Inspection.—The glands in the neck, when cut into, exhibited a firm cartiliginous structure, without any appearance of softening or suppuration. The glands of the vessels in the chest were in the same state. The lungs generally healthy; there was a considerable quantity of fluid in the peritoneal cavity. The glands accompanying the aorta, the spleen



(1798-1866)

LEUKEMIA &
LYMPHOMA
SOCIETY™

6

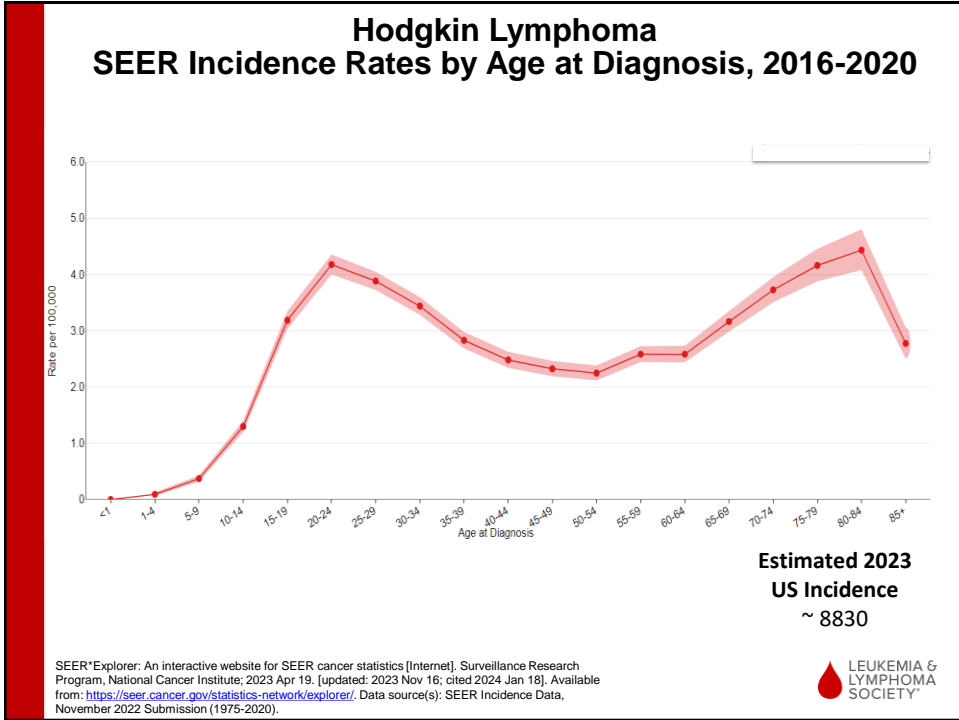

9

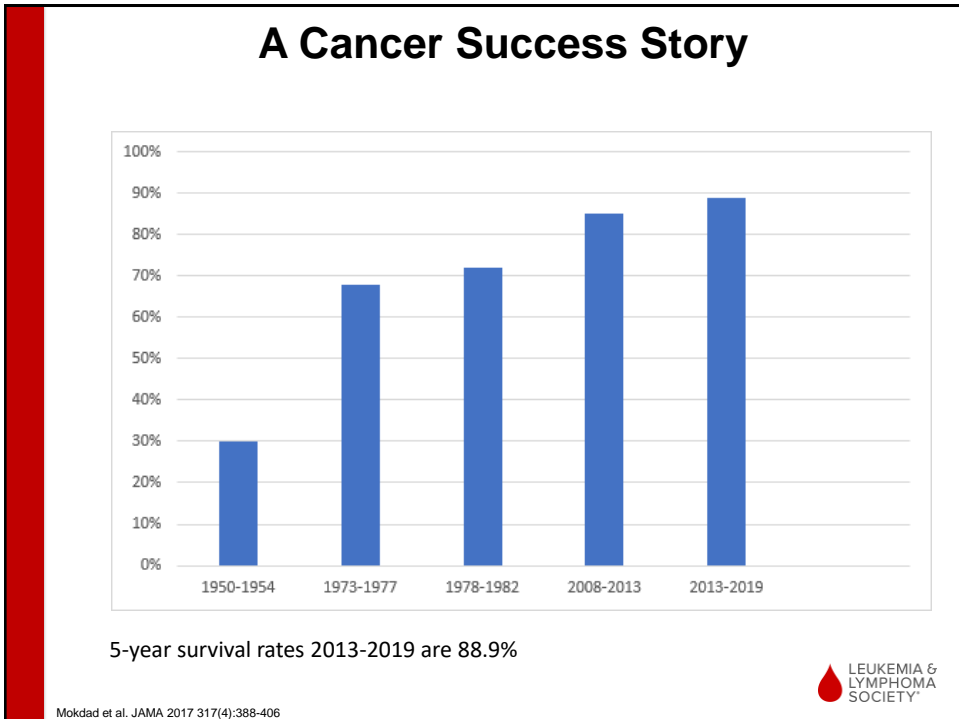

10

What Are the Signs of Hodgkin lymphoma?

Non-tender lymph node enlargement (localized)

- Neck, collarbone, armpit most commonly
- Middle of chest (mediastinum) on X-rays or scans
- Groin or pelvis less common

“B symptoms”

- Recurring fevers
- Drenching night sweats
- Unexplained weight loss (10%)

Other symptoms

- Fatigue, itchiness without rash
- Cough, chest pain, or shortness of breath
- Aching pain in chest or areas of swollen nodes after drinking alcohol



11

“Staging” Hodgkin lymphoma

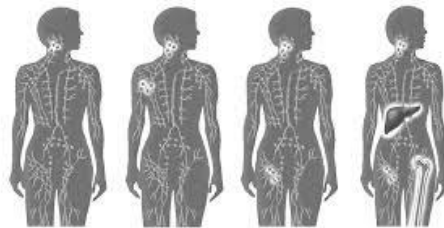

Stage I	Stage II	Stage III	Stage IV
Early Stage: Favorable		Advanced Stage	
Early Stage: Unfavorable			



12

Roadmap

Overview of Hodgkin lymphoma

Treatment of newly diagnosed Hodgkin lymphoma

Treatment of relapsed or refractory disease

Emerging and novel therapies



LEUKEMIA &
LYMPHOMA
SOCIETY

13

Treatment of Hodgkin lymphoma



LEUKEMIA &
LYMPHOMA
SOCIETY

14

Early Stage Favorable HL

1,190 patients with early stage (stage I/II), no risk factors

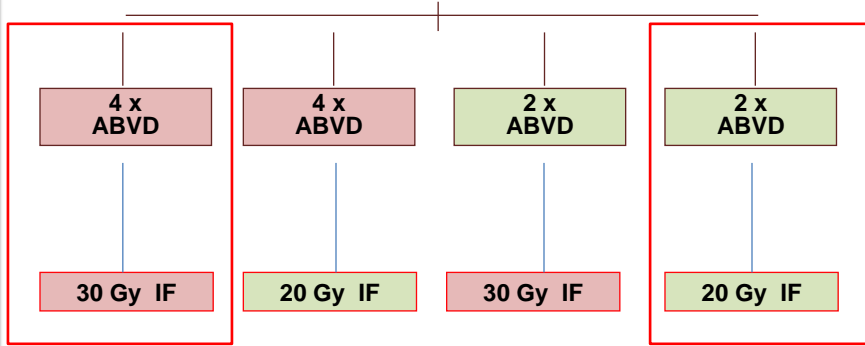

ABVD: doxorubicin hydrochloride (Adriamycin®), bleomycin sulfate (Blenoxane®), vinblastine sulfate (Alkaban-AQ®), and dacarbazine (DTIC-Dome®)
 Gy: amount of radiation used in photon radiation therapy is measured in grays; IF: involved-field radiation therapy
 Engert A et al. *N Engl J Med.* 2010;363:640-652.



15

“Freedom from Treatment Failure” Overall Survival

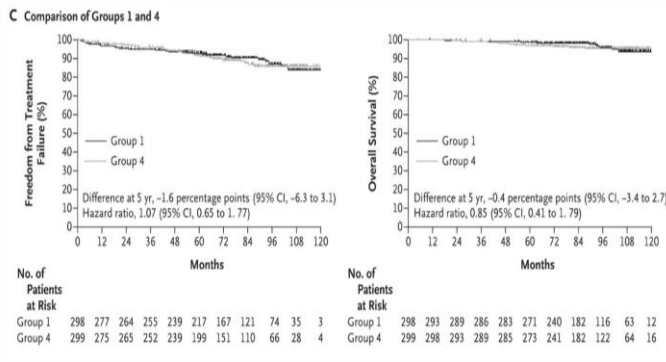

Most vs Least treatment:
ABVD x 4 + 30 Gy
vs
ABVD x 2 + 20 Gy

ABVD: doxorubicin hydrochloride (Adriamycin®), bleomycin sulfate (Blenoxane®), vinblastine sulfate (Alkaban-AQ®), and dacarbazine (DTIC-Dome®)
 Engert A et al. *N Engl J Med.* 2010;363:640-652.



16

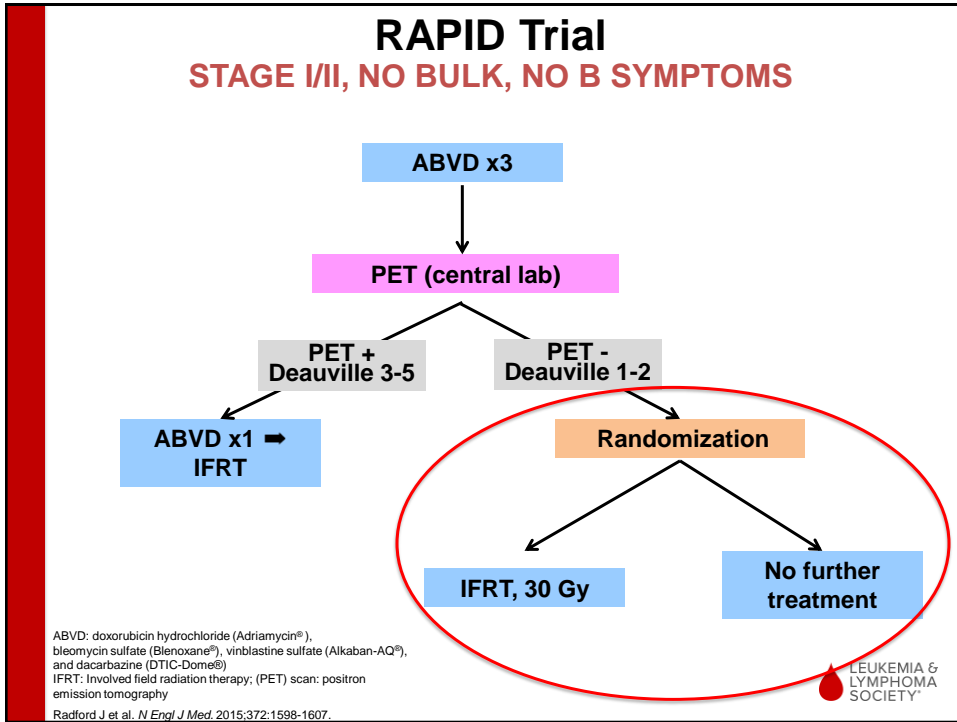

17

“Deauville” Criteria for PET Scan Results

Score	FDG-PET / CT scan result
1	No uptake above background
2	Uptake \leq mediastinum
3	Uptake $>$ mediastinum but \leq liver
4	Uptake moderately more than liver uptake, at any site
5	Markedly increased uptake at any site or new sites of disease

(For RAPID: Only scores of 1 or 2 = PET negative)

LEUKEMIA & LYMPHOMA SOCIETY

18

RAPID's Results in the PET-Negative Patients

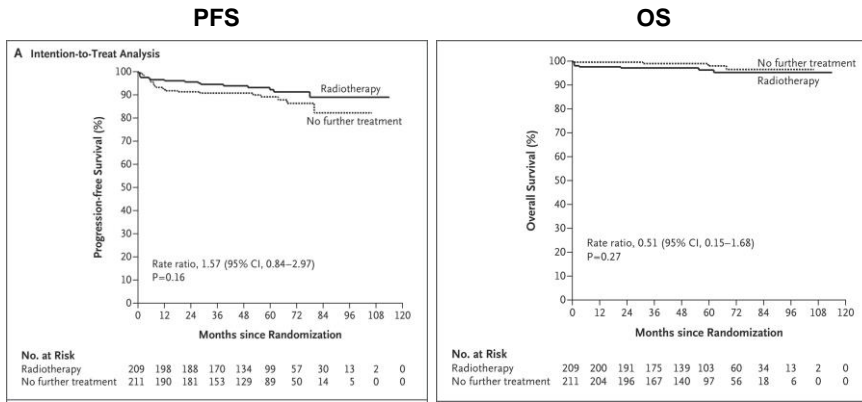

PFS: Progression-Free survival; OS: Overall Survival
Radford J et al. *N Engl J Med.* 2015;372:1598-1607.



19

CALGB 50604 Design

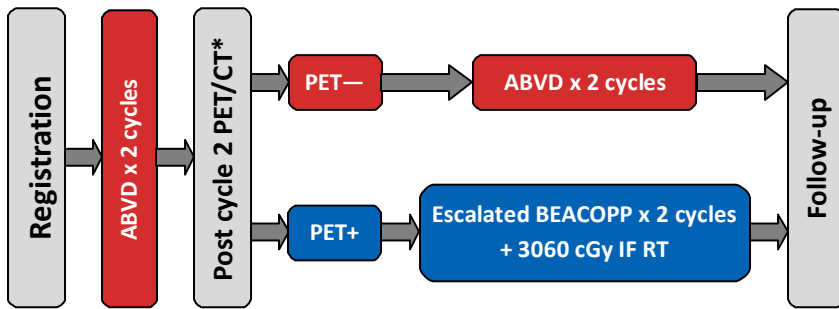

Phase II trial in newly-diagnosed stages I/II non-bulky HL conducted in Intergroup (CALGB/Alliance, SWOG, ECOG)

Prophylactic G-CSF only after febrile neutropenia or neutropenia and infection with ABVD. Prophylactic G-CSF with escalated BEACOPP.

G-CSF: prophylactic granulocyte colony-stimulating factor
BEACOPP: A chemotherapy regimen consisting of bleomycin (Blenoxane®), etoposide (Toposar®), doxorubicin hydrochloride (Adriamycin®), cyclophosphamide (Cytoxan®), vincristine (Oncovin®), procarbazine (Matulane®) and prednisone
ECOG: Eastern Cooperative Oncology Group
SWOG: Southwest Oncology Group



20

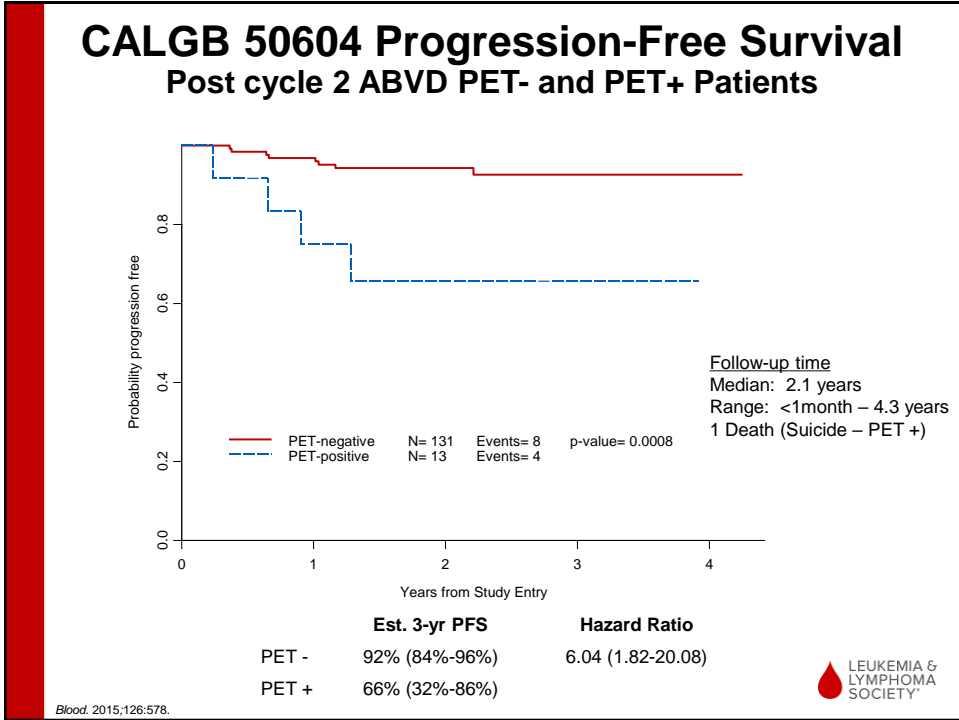

21

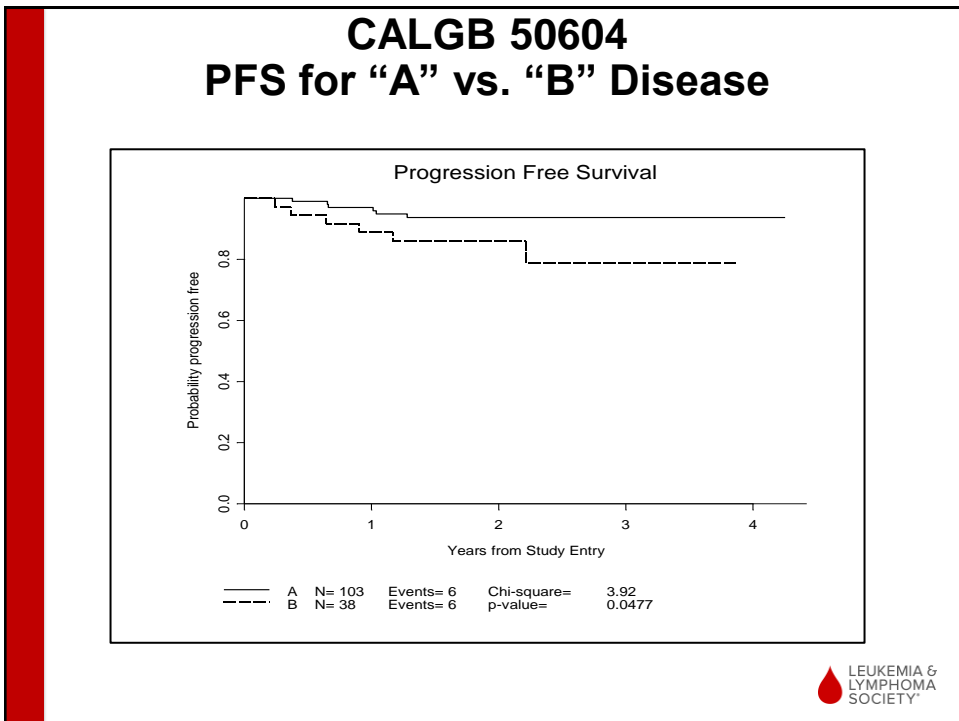

22

Breaking Down ABVD

Adriamycin® (doxorubicin)	Bleomycin (Blenoxane®)	Vinblastine (Alkaban-AQ®)	Dacarbazine (DTIC-Dome®)
Mechanism: - Intercalates b/w base pairs, inhibits topo II	Mechanism: - Causes single and double strand DNA breaks	Mechanism: - Inhibits microtubule formation	Mechanism: - Alkylating agent (active metabolite; MTIC)
Admin: Intravenous	Admin: Intravenous	Admin: Intravenous	Admin: Intravenous
AE: - Vesicant - Cardiomyopathy - Nausea (moderate) - Secondary malignancies - Discoloration of urine	AE: - Pulmonary fibrosis - Interstitial pneumonitis - Hyperpigmentation - Mucositis - Fever/chills	AE: - Vesicant - Myelosuppression - Mucositis - Intrathecal admin → fatal (ISMP 2014) - Peripheral neuropathy	AE: - Myelosuppression - Nausea (high) - Flu-like malaise - Photosensitivity
Organ dysfunction: - Renal: none - Hepatic: consider adj for Tbili > 1.2 or AST/ALT > 2X ULN	Organ dysfunction: - Renal: consider adj for CrCl < 50 mL/min - Hepatic: none	Organ dysfunction: - Renal: none - Hepatic: consider adj for Tbili > 1.5 or AST/ALT > 2X ULN	Organ dysfunction: - Renal: consider adj for CrCl < 60 mL/min - Hepatic: none
DDI: - CYP3A4, 2D6 (major) - P-glycoprotein	DDI: - None	DDI: - CYP3A4 (major) - P-glycoprotein	DDI: - CYP1A2 (major)



23

Supportive Care for ABVD

Bleomycin Pulmonary Toxicity

- Risk Factors
 - >400 units lifetime dose
 - Elderly
 - Prior radiation therapy
 - Renal dysfunction
 - History of lung disease
- Monitoring
 - Baseline PFT's, DLCO – prn during therapy
- Growth factor
 - Safe to treat through neutropenia without dose reduction (requires prophylaxis against fungus and PJP)
 - Concern that growth factor could increase risk of BPT, but recent data question this (*Binder AF et al. Int J Hematol Oncol Stem Cell Res 2017*).

Extravasation

- Vesicants
 - Erythema, blistering, necrosis of tissues
 - "DNA binding vesicant"
 - Doxorubicin, mechlorethamine
 - "Non-DNA binding vesicant"
 - Vinblastine
- Management
 - Stop infusion, aspirate any drug
 - Do not flush line
 - Apply compress
 - Vinblastine – warm
 - Doxorubicin – cold
 - Drug-specific
 - Doxorubicin
 - Dexrazoxane
 - DMSO (dimethyl sulfoxide)
 - Vinblastine
 - Hyaluronidase



24

Escalated BEACOPP

- **B**leomycin (Blenoxane®) – day 8
- **E**toposide (Toposar®) – days 1-3
- **A**driamycin® (doxorubicin) – day 1
- **C**yclophosphamide (Cytoxan®) – day 1
- **Q**ncovin® (vincristine) – day 8
- **P**rednisone – oral, days 1-14
- **P**rocarbazine (Matulane®) – oral, days 1-7

* Repeat every 21 days with growth factor support.



25

Escalated BEACOPP

- **B**leomycin (Blenoxane®) – day 8
- **E**toposide (Toposar®) – days 1-3
- **A**driamycin® (doxorubicin) – day 1
- **C**yclophosphamide (Cytoxan®) – day 1
- **Q**ncovin® (vincristine) – day 8
- **P**rednisone – oral, days 1-14
- **P**rocarbazine (Matulane®) – oral, days 1-7

Every 21 days with growth factor support.

Adverse Effect	COPP-ABVD	Std BEACOPP	Esc BEACOPP
Leukopenia (grade 4)	19%	37%	90%
Thrombocytopenia (grade 4)	2%	3%	47%
Anemia (grade 4)	1%	1%	15%
Infection (grade 4)	1%	3%	8%
Mucositis (grade ≥ 3)	1%	2%	8%
Alopecia (grade ≥ 3)	36%	75%	79%

Diehl V et al. *N Engl J Med.* 2003;348:2386-95.



26

Escalated BEACOPP

- **B**leomycin (Blenoxane®)– IV push, day 8
- **E**toposide (Toposar®)– IV infusion, days 1-3
- **A**driamycin® (doxorubicin) – IV push, day 1
- **C**yclophosphamide (Cytoxan®) – IV infusion, day 1
- **O**ncovin® (vincristine) – IV infusion, day 8
- **P**rednisone – oral, days 1-14
- **P**rocarbazine (Matulane®) – oral, days 1-7
 - Highly emetogenic (>90%)
 - Prophylaxis
 - Consider evening dosing
 - Disulfiram-like reaction (EtOH)
 - MAO* inhibitor
 - Drug interactions
 - Avoid tyramine-containing foods
 - Aged Cheeses, Pepperoni, Pickled Foods
 - Wine
 - CNS depression
 - Typically restricted to a specialty pharmacy, requiring prior authorization

*MAO: monoamine oxidase



27

Appropriate Chemotherapy Dosing for Obese Adult Patients with Cancer

- Use **full weight-based** chemotherapy doses (unless specifically noted) when therapeutic goal is cure
- **Toxicity not shown to be increased** for obese patients receiving full weight-based doses
 - Obese patients receiving full doses of chemotherapy experience similar or less myelosuppression
- Concern regarding **under-dosing** and inferior outcomes if dose-capping were to be utilized

Griggs JJ et al. *Jourm Clin Oncol*. 2012;30(13):1553-1561.



28

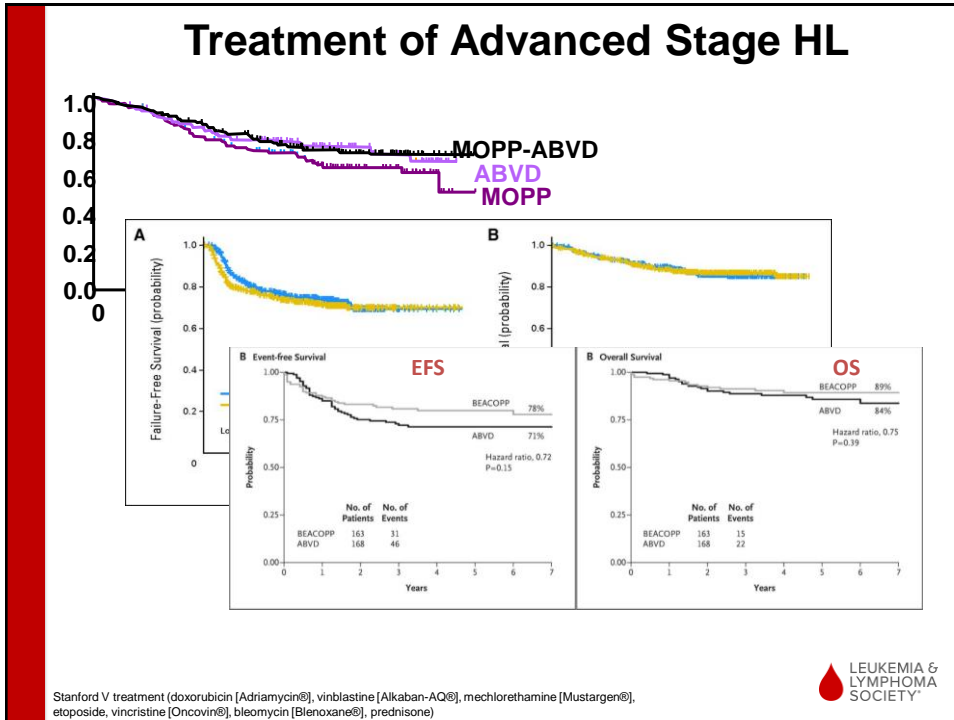

29

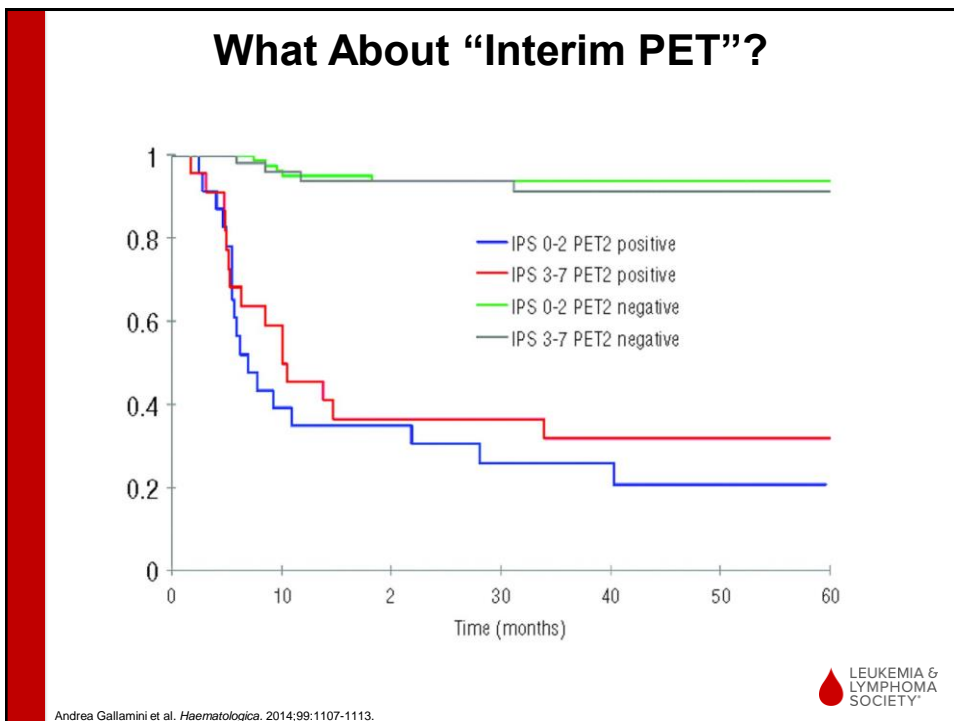

30

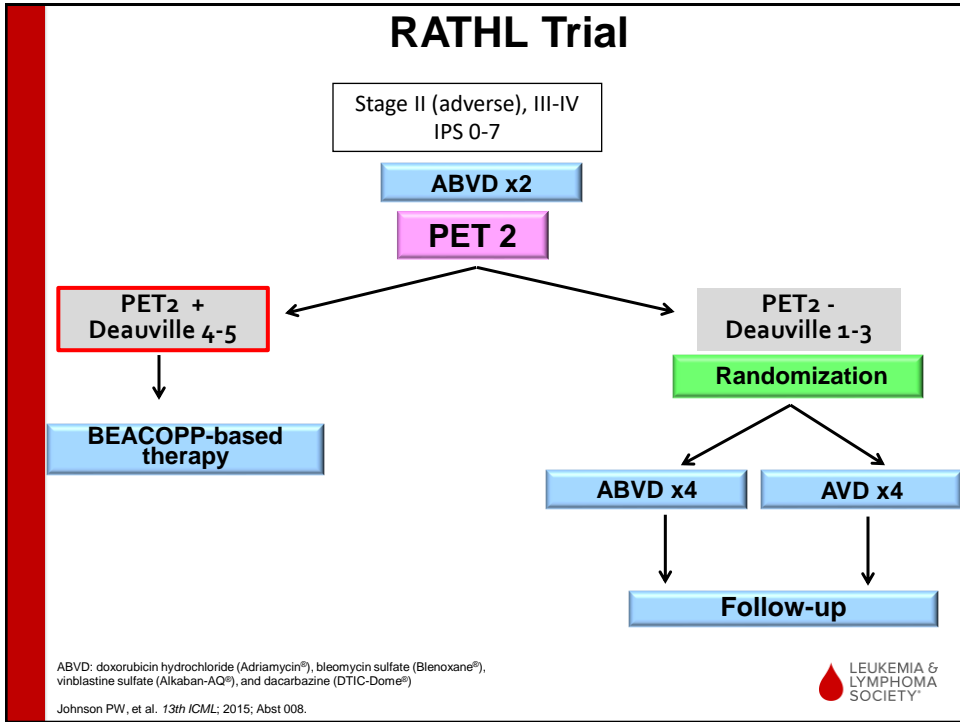

31

How'd the PET2 Negative Patients do?

	ABVD N=469	AVD N=466
Complete remission	65%	69%
Deaths (N)	14	14
3-yr PFS	85.4%	84.4%
3-yr OS	97.1%	97.4%
Severe lung disease	3.6%	0.6% (P=.002)

ABVD: doxorubicin hydrochloride (Adriamycin®), bleomycin sulfate (Blenoxane®), vinblastine sulfate (Alkaban-AQ®), and dacarbazine (DTIC-Dome®)

LEUKEMIA & LYMPHOMA SOCIETY™

32

Brentuximab vedotin (Adcetris®): ADC (Antibody-Drug Conjugate)

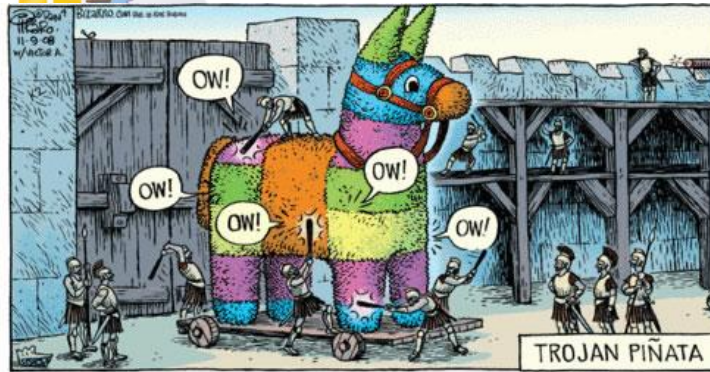

Toxin disrupts cell mitosis



Mitosis fails

Cell death

Younes A et al. *N Engl J Med.* 2010; 363:1812-21 (appendix).



33

Brentuximab (Adcetris®) in Multiply Relapsed HL

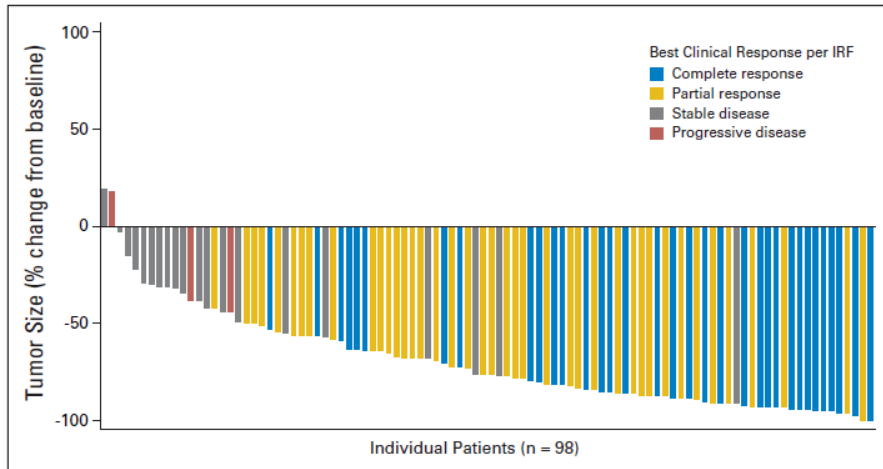

IRF: independent review facility
Younes A et al. *J Clin Oncol.* 2012;30: 2183-9.

34

ECHELON-1: BV+AVD vs ABVD in Advanced cHL

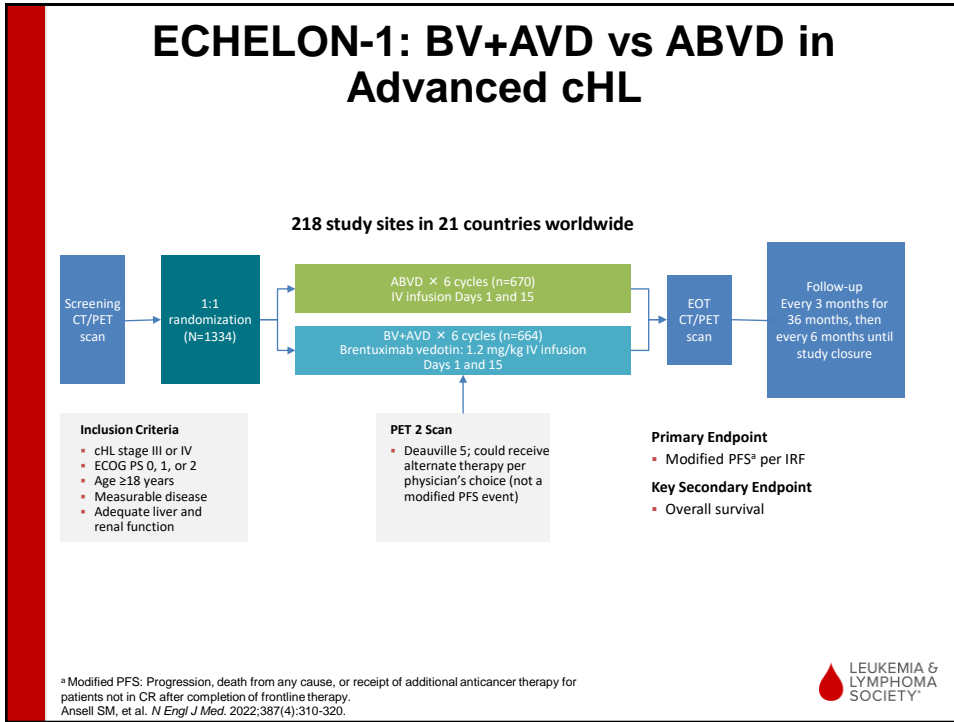

35

ECHELON-1: PFS Per Investigator at 5-Year Follow-up

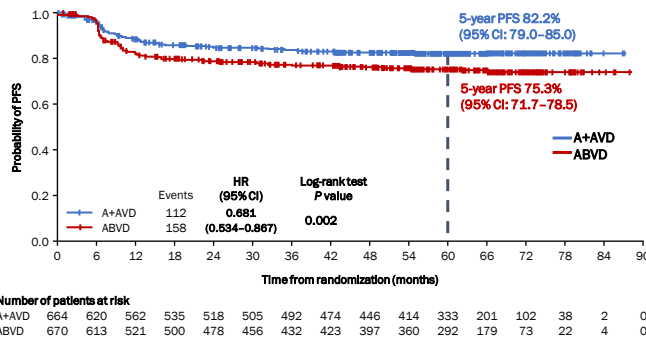

Straus DJ, et al. Presented at: 62nd ASH Annual Meeting, December 5-8, 2020 [Virtual], Abstract 2973.



36

ECHELON-1: 5-year PFS Rates by PET2 Status

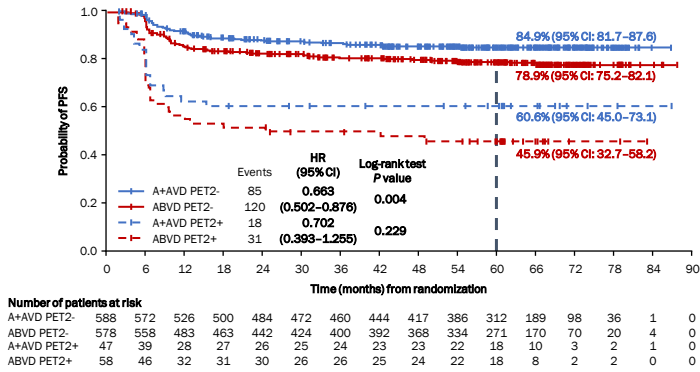

Straus DJ, et al. Presented at: 62nd ASH Annual Meeting, December 5-8, 2020 [Virtual]. Abstract 2973.



37

ECHELON-1: Overall Survival

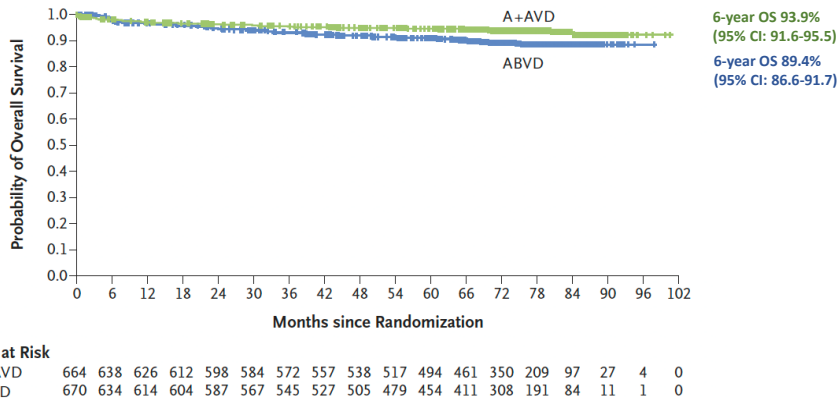

38

ECHELON-1: G-CSF Primary Prophylaxis and Effects on Neutropenia with BV+AVD Treatment

BV+AVD: Neutropenia Rate, by Grade, With and Without G-CSF Primary Prophylaxis

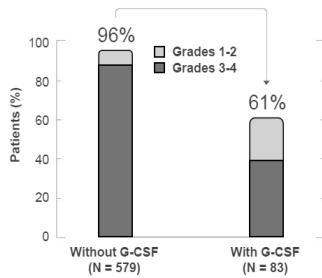

BV+AVD: Febrile Neutropenia Rate, Any Grade, With and Without G-CSF Primary Prophylaxis

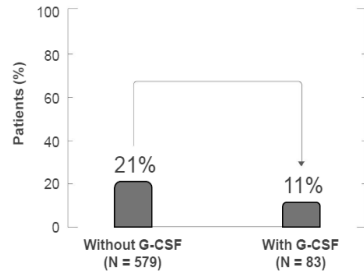

39

ECHELON-1: Peripheral Neuropathy Resolution and Improvement

Patients With Complete Resolution or Improvement of PN Over Time (%)

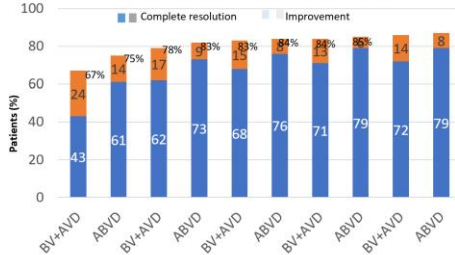

Patients With Ongoing PN by Grade at 6-Year Follow-Up⁵

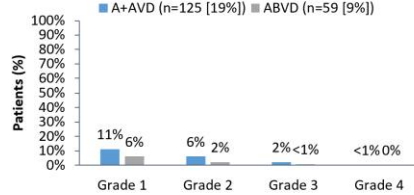

40

ECHELON-1: Pregnancy Data

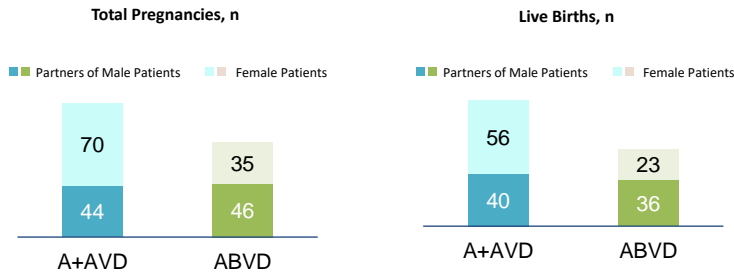

- 195 pregnancies were reported among patients and their partners (A+AVD: 114; ABVD: 81)
- No still births were reported in either arm



41

Brentuximab Vedotin (Adcetris®)

- Indication(s)
 - Previously untreated stage 3-4 cHL (**in combination with AVD**)
 - Relapsed cHL following 2 or more therapies or following ASCT
 - Consolidation** in cHL patients at high risk of relapse post-ASCT
- Dosing
 - 1.2-1.8 mg/kg (max weight: **100 kg**) every 2-3 weeks (depending on indication)
 - IV infusion over 30 minutes
 - No routine premedications
- Precautions/Warnings
 - BBW: Progressive multifocal leukoencephalopathy (PML)
 - Myelosuppression, infection
 - Dermatologic
 - Renal
 - CrCl < 30 mL/min: contraindicated
 - MMAE excreted renally, inc grade 3/4 toxicities in severe impairment
 - Hepatic
 - CP A: Reduce dose (1.8 → 1.2 mg/kg, 1.2 → 0.9 mg/kg)
 - CP B/C: Avoid use
 - MMAE** metabolized hepatically, 2.2 fold inc in AUC in hepatic impairment

AVD: Adriamycin® (doxorubicin), vinblastine, dacarbazine; ASCT: autologous stem cell transplant;
CP: Child Pugh; MMAE: monomethyl auristatin E



42

Roadmap

Overview of Hodgkin lymphoma

Treatment of newly diagnosed Hodgkin lymphoma

Treatment of relapsed or refractory disease

Emerging and novel therapies



LEUKEMIA &
LYMPHOMA
SOCIETY

43

Treatment of Relapsed / Refractory HL

Three main types of treatments

Chemotherapy (ICE⁺, GVD^{*}, bendamustine)

Brentuximab vedotin (if not used yet)

”Checkpoint inhibitors” (nivolumab, pembrolizumab)

Treatment programs often combine them:

Pembrolizumab + GVD

Brentuximab + nivolumab

Brentuximab + bendamustine

Goal is usually

- 1) Remission, and then
- 2) Autologous (self) stem cell transplant

ICE⁺ ifosfamide, carboplatin, and etoposide
GVD: gemcitabine, vinorelbine, doxorubicin

LEUKEMIA &
LYMPHOMA
SOCIETY

44

Immunotherapy in HL: “Checkpoint Inhibitors”

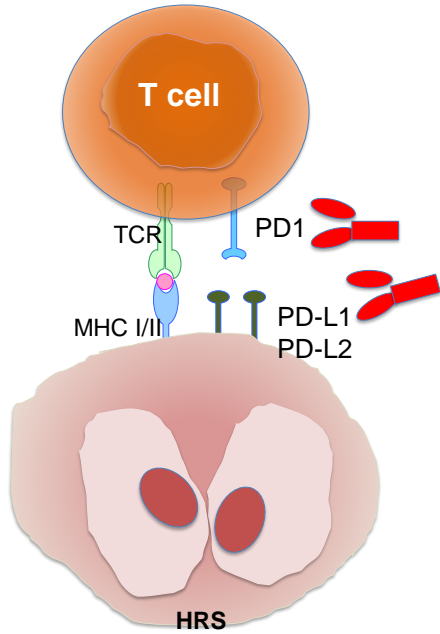

HRS: Hodgkin Reed-Sternberg Cell
Adapted from Stathis & Younes: Ann Oncology 2015.



45

Nivolumab (Opdivo®) in Multiply Relapsed HL

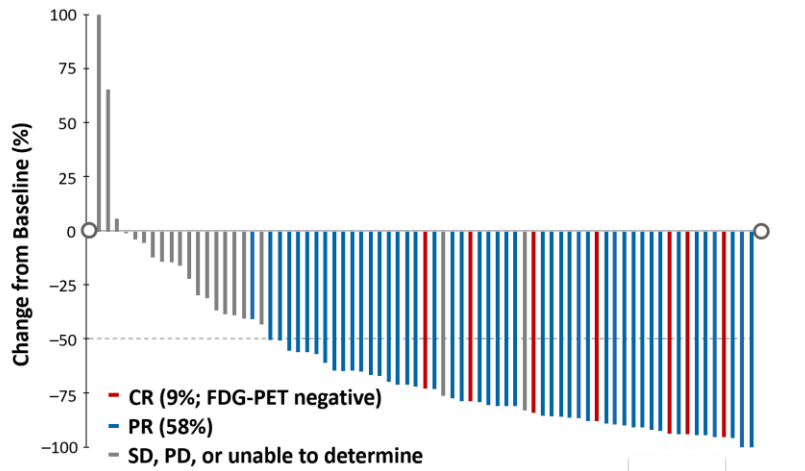

CheckMate 205B
Per IRRC assessment.

46



46

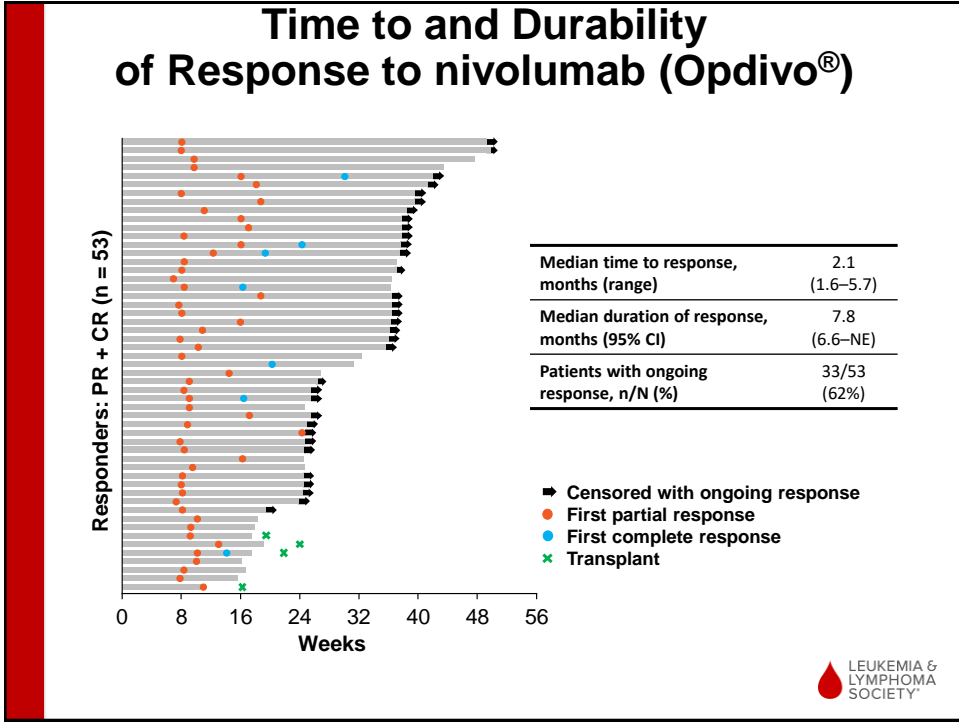

47

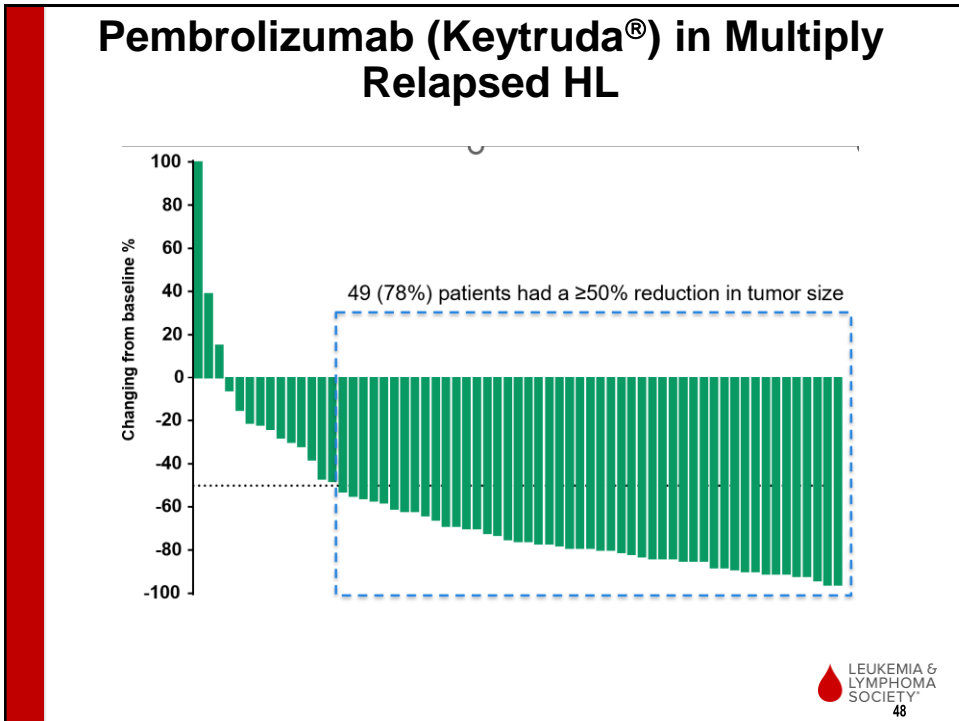

48

Pembrolizumab (Keytruda®) in Multiply Relapsed HL

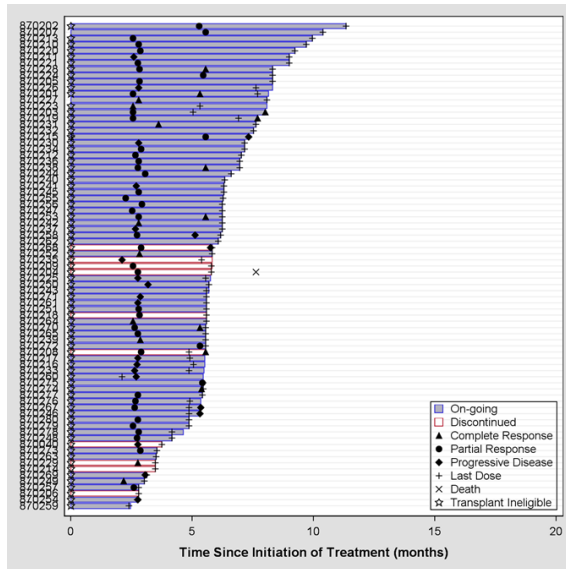

Median number of treatment cycles:
9 (range, 1-17)

Majority of patients on ongoing treatment at data cutoff

*Data cutoff: June 27, 2016.



49

Checkpoint Blockade in HL

Nivolumab (Opdivo®)

- Indication(s)
 - Relapse following **ASCT** and **brentuximab vedotin** (Adcetris®), or following **3 or more lines** of therapy including ASCT
 - Continue until disease progression or toxicity
- Dosing/Administration
 - 240 mg q2 weeks or 480 mg q4 weeks
 - FLAT dosing
 - IV infusion over 30 minutes
 - No routine premedications
- Precautions/Warnings
 - Immune-mediated toxicities
 - History of autoimmune disorders
 - Allo-SCT complications

Pembrolizumab (Keytruda®)

- Indication(s)
 - Relapse following **3 or more lines** of therapy (independent of PD-L1 expression)
 - Continue until disease progression, toxicity, or **up to 24 months**
- Dosing/Administration
 - 200 mg q3 weeks
 - FLAT dosing
 - IV infusion over 30 minutes
 - No routine premedications
- Precautions/Warnings
 - Immune-mediated toxicities
 - History of autoimmune disorders
 - Allo-SCT complications



50

“ITIS”

Hypothyroidism
Hyperthyroidism
Pneumonitis
Colitis

Word of Caution: Avoid these agents when there is a history of bleomycin, brentuximab, or gemcitabine-associated pneumonitis that required steroid support



51

Auto-transplant for Relapsed/Refractory HL

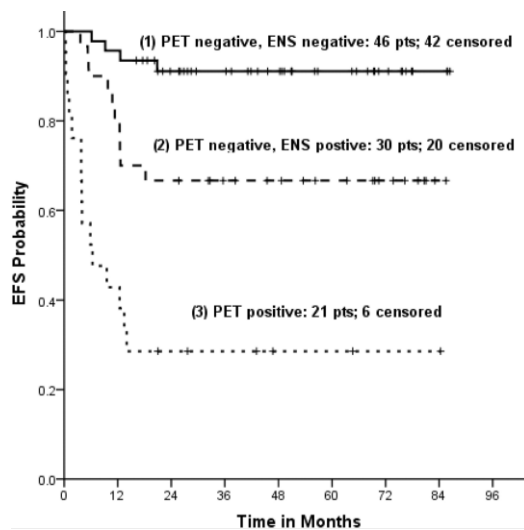
Moskowitz C H et al. *Blood*, 2012.

52

The AETHERA Study

329 patients were randomized at 78 sites in North America and Europe

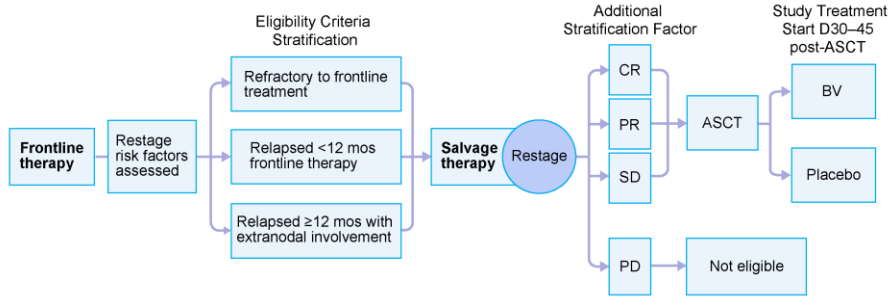

CR: Complete Response; PR: Partial Response; SD: Stable Disease; PD: Primary Disease
 Moskowitz C, et al. *Lancet*. 2015.



53

AETHERA: Results

Progression-free survival

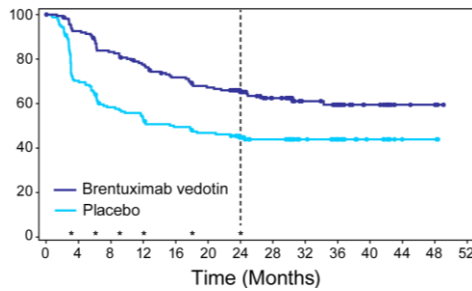

Overall survival

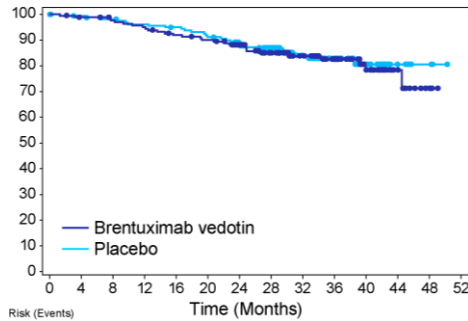

Moskowitz C, et al. *Lancet*. 2015.



54

Who Benefits the Most?

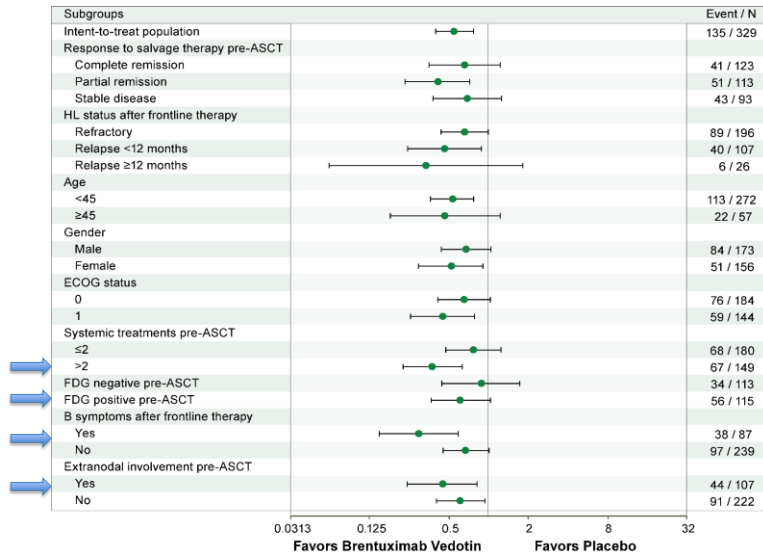

Moskowitz C, et al. *Lancet*. 2015.



55

Roadmap

Overview of Hodgkin lymphoma

Treatment of newly diagnosed Hodgkin lymphoma

Treatment of relapsed or refractory disease

Emerging approaches

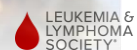

56

Moving Treatment of Newly Diagnosed HL Forward

Given the success of checkpoint inhibitors in patients with relapsed disease, can they be incorporated into first-treatment to improve outcomes?



57

S1826 Intergroup Study

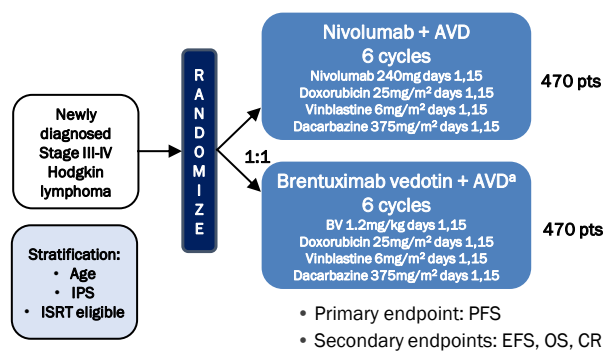

^aG-CSF is mandatory in BV-AVD arm, optional in N-AVD arm



Herrera AF, et al. Presented ASH 2020. December 5-8, 2020 (Virtual). Abstract 2969.

58

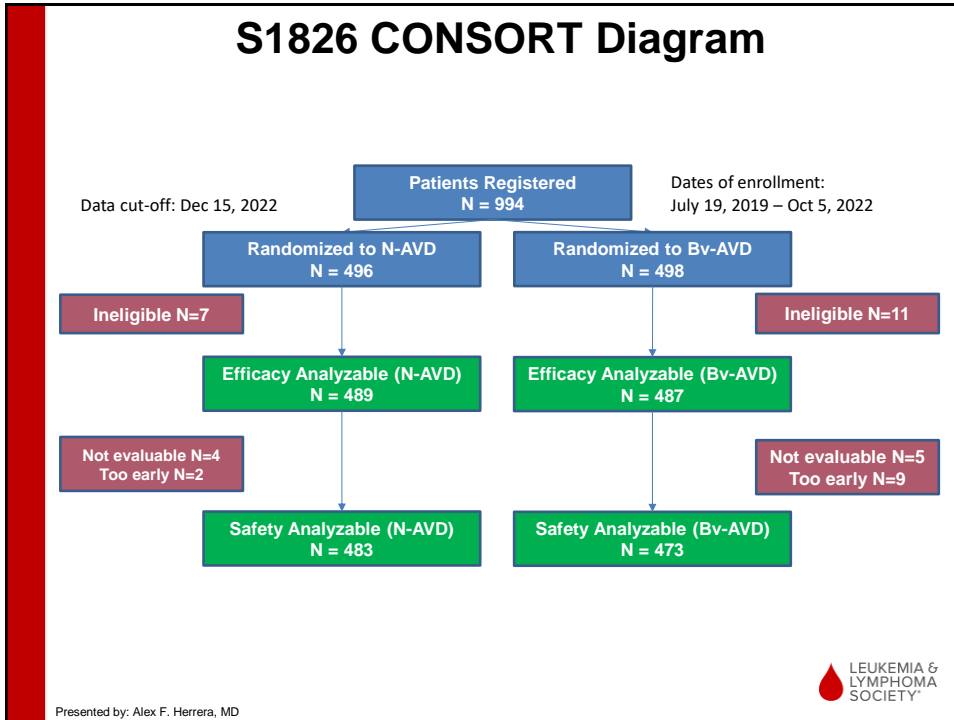

59

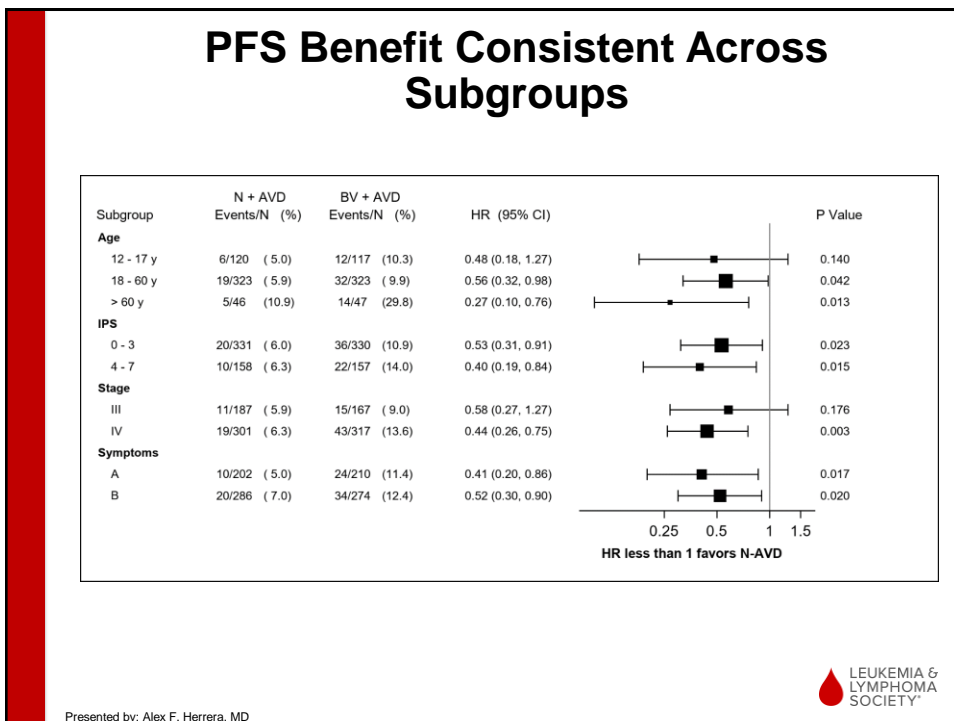

60

S1826: PFS AT 1 YEAR

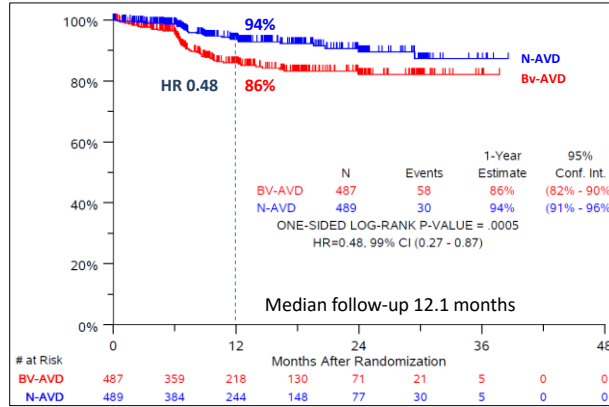

1-year PFS
N-AVD 94%
Bv-AVD 86%

Presented by: Alex F. Herrera, MD



61

Overall Survival

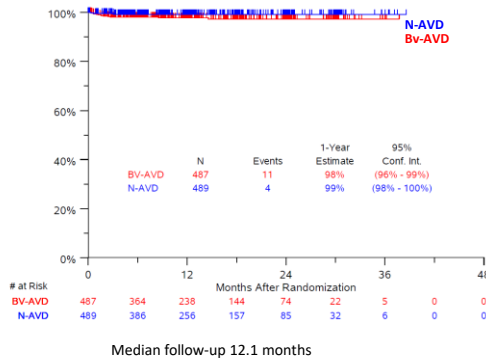

Cause of death	N-AVD	Bv-AVD
Infection	2	4
Sepsis	1	2*
Cardiac arrest	0	1
Pneumonitis	0	1
Dehydration, vomiting, cHL	0	1
cHL	1**	0
Unknown	0	2
Total OS events	4	11

* 1 death from COVID-19/sepsis
 ** never received treatment, unevaluable for toxicity

Presented by: Alex F. Herrera, MD



62

Brentuximab Vedotin, Nivolumab, Doxorubicin, and Dacarbazine (AN+AD) for Advanced-Stage Classical Hodgkin Lymphoma: Updated Efficacy and Safety (SGN35-027)

Open label, multiple part Phase 2 clinical trial
 Part B enrolled patients with Stage II bulky mediastinal, Stage III or Stage IV cHL
 Patients received up to 6 cycles of AN+AD
 Primary endpoint is CR rate at EOT
 Key secondary endpoints include safety, tolerability, ORR, DOR, DOCR and PFS

Study Design^a - Part B

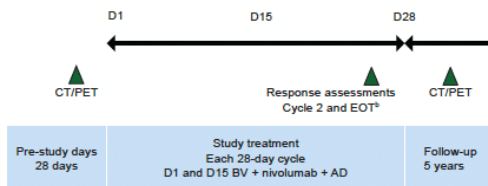

^aDisease response was assessed by Lugano 2014⁹ and LYRIC¹⁰ at Cycle 2 and at EOT. ^bResponse assessments include PET and diagnostic-quality CT scan on Day 25 to 28 of Cycle 2, and at EOT.



63

SGN35-027 Part B: PFS

Progression-Free Survival

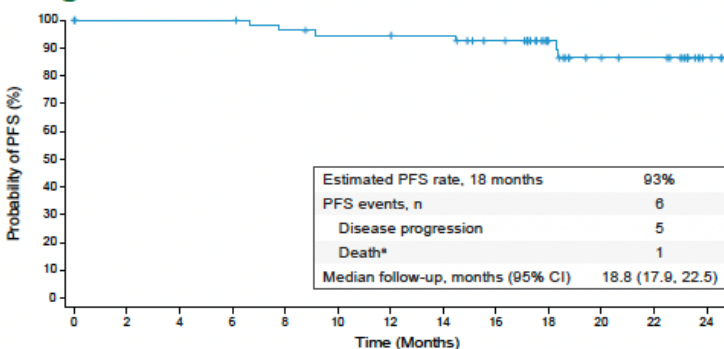

N at risk (events): 57(0) 56(0) 56(0) 56(0) 53(2) 51(3) 51(3) 50(3) 45(4) 30(4) 22(6) 19(6) 6(6)

*Patient died from sepsis secondary to aspiration pneumonia and bacteremia after safety reporting period.



64

AHOD 2131: Newly Diagnosed Early Stage Hodgkin Lymphoma

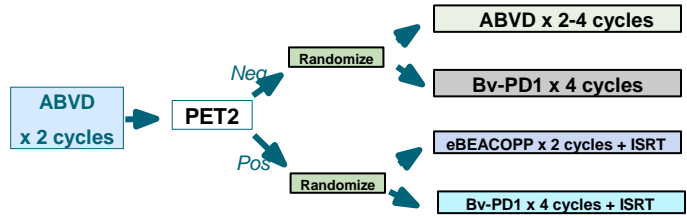

Sample Size Projections:
n=1782 over 5 years-
PET neg - 1514
PET pos - 268



65

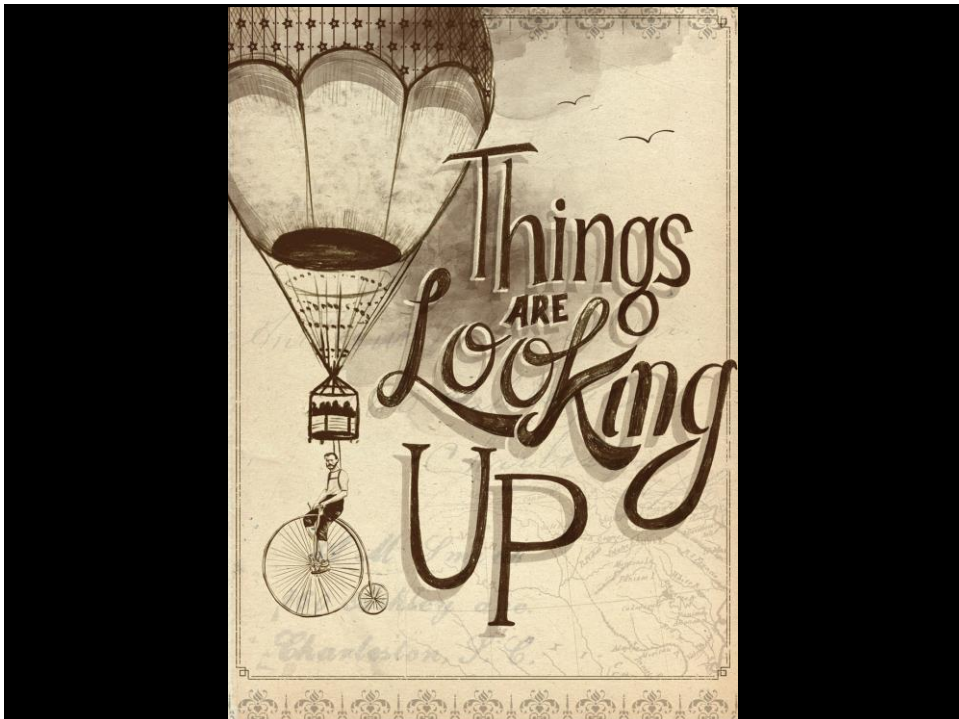

66

Thank You



67

**Hodgkin's Lymphoma and
Nursing Care**

Tara McCabe, APN, AOCNP, MSN
Advanced Practice Nurse
Rutgers Cancer Institute of New Jersey
New Brunswick, NJ



68

Role of the APP and RN

- Helps to coordinate care
- Addresses any patient concerns/questions
- Medication Compliance
- Symptom Management



69

Initial Diagnosis

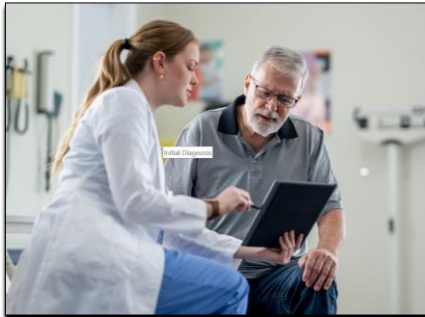

- Review diagnosis
- Discuss treatment plan
- Address any questions
- Review medications and side effect profiles
- Financial/social support



70

Treatment Planning

- What to expect at each visit
 - Timing, IV access, blood draws
- Cycle calendars
- Chemotherapy teaching
- Medication schedule
- Imaging Schedule

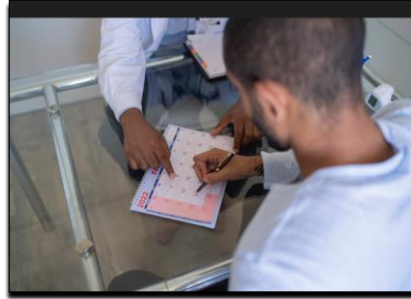

71

Symptom Management

GI Side Effects

- Nausea/Vomiting
 - Antiemetics
 - Need for IV hydration
- Diarrhea
 - Antidiarrheals
- Constipation
 - Assess nutritional intake
 - Bowel regimen
 - Activity status

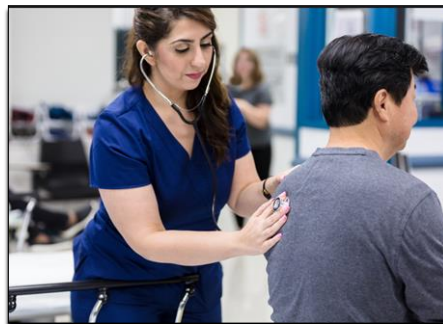

72

Symptom Management

Pain

- Role of nonopioids vs opioids
- Severity and location

Fatigue

- Activity status
- Sleep hygiene

Peripheral Neuropathy

- Early identification
- Management



73

Symptom Management

Myelosuppression

- Anemia
- Neutropenia
- Thrombocytopenia

Role of Prophylaxis

- Antiviral
- Antifungal
- Antibiotic



74

Mid Cycle Treatment and Assessment

End of cycle 2 scan

PET response – what this means for further treatment

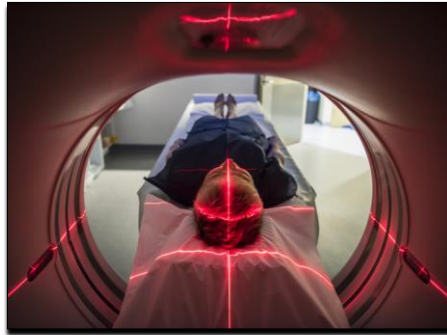

75

END OF TREATMENT PLANNING AND ASSESSMENT



- End of treatment PET scan
- Central line removal discussion
- Begin the discussion of active surveillance and survivorship



76

Active Surveillance and Survivorship

- For first 2 years clinic visit every 3 months
- Scans every 6 months
- After year 2, clinic visits are spaced out to every 6 months and annual scans



77

Conclusion and Final Thoughts

- The APP and RN are a crucial support network for patients and caregivers.
- Collaborative approach leads to better outcomes
- Autonomy when treating patients



78

FREE LLS RESOURCES FOR HEALTHCARE PROVIDERS

- ❑ CME & CE courses: www.LLS.org/CE
- ❑ Fact Sheets for HCPs: www.LLS.org/HCPbooklets
- ❑ Videos for HCPs: www.LLS.org/HCPvideos
- ❑ Podcast series for HCPs: www.LLS.org/HCPpodcast

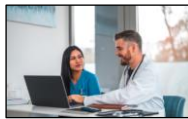

79

FREE LLS RESOURCES FOR PATIENTS

- ❑ **Information Specialists** – Personalized assistance for managing treatment decisions, side effects, and dealing with financial and psychosocial challenges (IRC).
 - www.LLS.org/IRC
- ❑ **Nutrition Education Services Center** – one-on-one consultation with a registered dietician for patients/caregivers of all cancer types (NESC).
 - www.LLS.org/Nutrition
- ❑ **Clinical Trial Nurse Navigators** – RNs and NPs provide a personalized service for patients seeking treatment in a clinical trial, sift through the information and provide information to bring back to their HC team (CTSC).
 - www.LLS.org/CTSC
- ❑ **Reach out Monday–Friday, 9 am to 9 pm ET**
 - Phone: (800) 955-4572
 - Live chat: www.LLS.org/IRC
 - Email: infocenter@LLS.org
 - HCP Patient Referral Form: www.LLS.org/HCPreferral



80

HERE TO HELP: LLS COMMITMENT

LLS is committed to providing education and resources to help patients access clinical trials.

CLINICAL TRIAL SUPPORT CENTER

- A team of highly trained nurses and nurse practitioners experienced with hematological malignancies and clinical research.
- Provide education to patients about clinical trials, treatment options, and other disease specific information.
- Provide patients, families, and their caregivers with a professional, detailed, individualized search to discuss with their HCP.
- Provide guidance and serve as advocates throughout the clinical trial process. Help make connections between the patient and the trial site to facilitate enrollment as appropriate.
- Provide a personal connection and develop long term relationships to help better serve our patients.



81

FREE LLS RESOURCES FOR PATIENTS AND CAREGIVERS

Webcasts, Videos, Podcasts, booklets:

- www.LLS.org/Webcasts
- www.LLS.org/EducationVideos
- www.LLS.org/Podcast
- www.LLS.org/Booklets
- www.LLS.org/Lymphoma

Support Resources

- ❑ Financial Assistance: www.LLS.org/Finances
 - Urgent Need
 - Patient Aid
 - Travel Assistance
- ❑ Other Support: www.LLS.org/Support
 - LLS Regions
 - Online Weekly Chats Facilitated by Oncology SW
 - LLS Community Social Media Platform
 - First Connection Peer to Peer Program

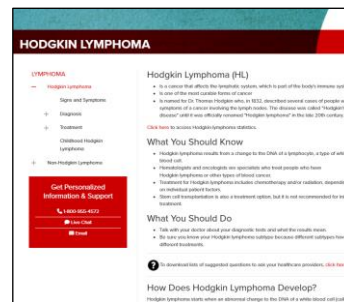

82

FREE LLS RESOURCES FOR YOUR PATIENTS

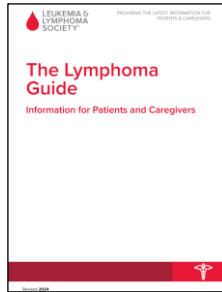
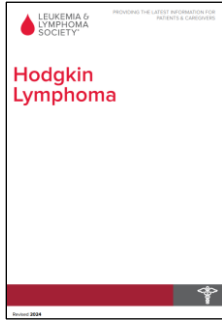

Booklets and Fact Sheets
English – www.LLS.org/Booklets
Spanish – www.LLS.org/Materiales



83

THANK YOU

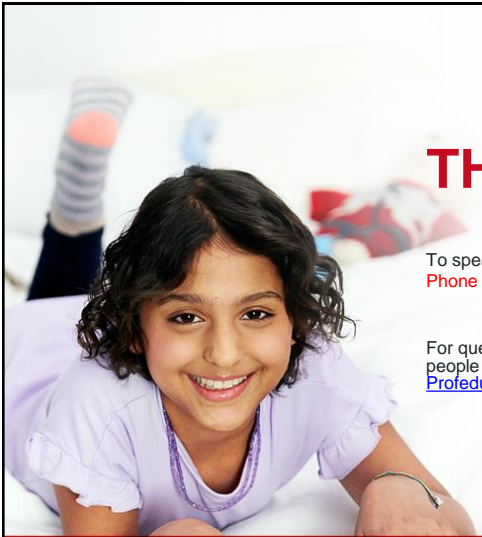

To speak with an Information Specialist or to refer a patient:
Phone (800) 955-4572 Email: Infocenter@LLS.org

For questions about this program, concerns, or assistance for people with disabilities or grievances, please contact us at Profeducation@LLS.org

We have one goal: A world without blood cancers



84